

STAINLESS METAL CRAFT

6 BROMLEY ROAD EMU PLAINS 2750
PHONE: (02) 4735 5666 FAX: (02) 4735 7950
E-MAIL info@smcstainless.com.au
www.smcstainless.com.au

THE STAINLESS STEEL PEOPLE

(SINCE 1962)

MATERIAL - GRADE 304 STAINLESS STEEL

RECESSED TUNDISH

OPTIONS

- * MARINE GRADE 316
- * OTHER FACE PLATE WINDOWS AVAILABLE
- * SECURITY FIXINGS



CLEAR
PERSPEX

* TYPICAL USE :
-- IN WALL DISCHARGE POINT FOR CONDENSATE / WATER

* HOSPITALS / AGED CARE / HOTELS / APARTMENT BUILDINGS
MEDICAL CENTRES / RENAL DIALYSIS

DATA
SHEET

ITEM: RECESSED TUNDISH

CODE: TU-RE-1A

DATE:

FEBRUARY - 2004

REV:

C

PAGE No:

163

STAINLESS METAL CRAFT

6 BROMLEY ROAD EMU PLAINS 2750
 PHONE: (02) 4735 5666 FAX: (02) 4735 7950
 E-MAIL info@smcstainless.com.au
www.smcstainless.com.au

THE STAINLESS STEEL PEOPLE

(SINCE 1962)

MATERIAL - GRADE 304 STAINLESS STEEL

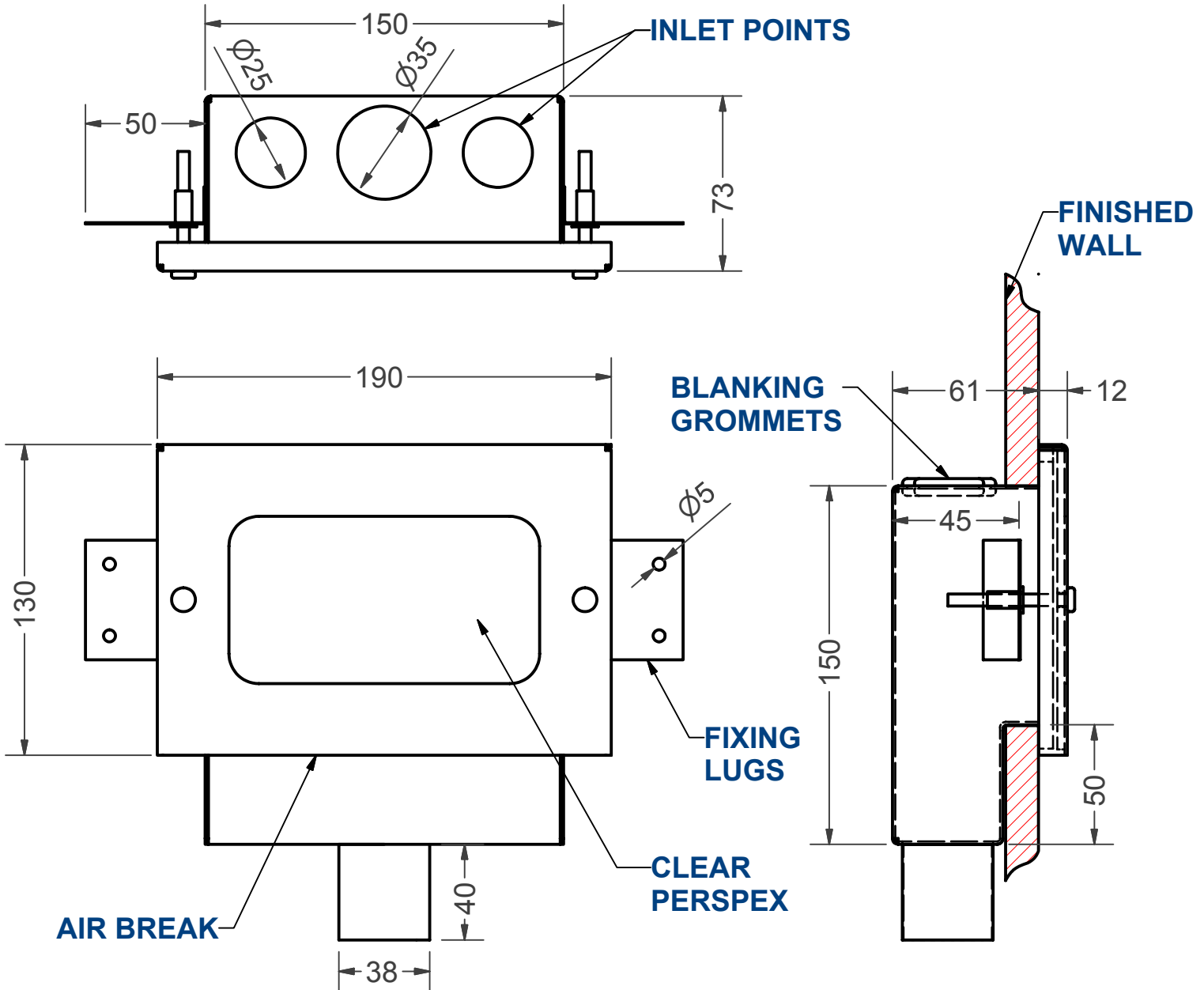

**SPECIFICATIONS -
 STAINLESS STEEL RECESSED TUNDISH
 SHALL BE MODEL TU-RE-1A FROM
 STAINLESS METAL CRAFT
 PHONE: 02 4735 5666**

**DATA
 SHEET**

ITEM: RECESSED TUNDISH

CODE: TU-RE-1A

DATE:

FEBRUARY - 2004

REV:

C

PAGE No:

163